

Little Lok 1200

With its ease of use the Little Lok 1200 can make short work of your channel letter fastening needs.

- 12" throat
- Fast cycle times
- Adjustable table accommodates up to 6" high letter
- UL recognized tooling*
- Simple tool adjustment
- Air powered

Designed and built by the company that sets the standard for the channel letter industry

*Norlok tooling components MP70001, MP70002, & MP70010. This is standard in all Letter Lok 1200 machines



INNOVATIONS IN ENGINEERING

CINCINNATI Precision Machinery, Inc.

www.cpmfab.com

513-860-4133

Little Lok 1200



The Little Lok 1200 is the smallest and most economical of Norlok's Letter Lok product line.

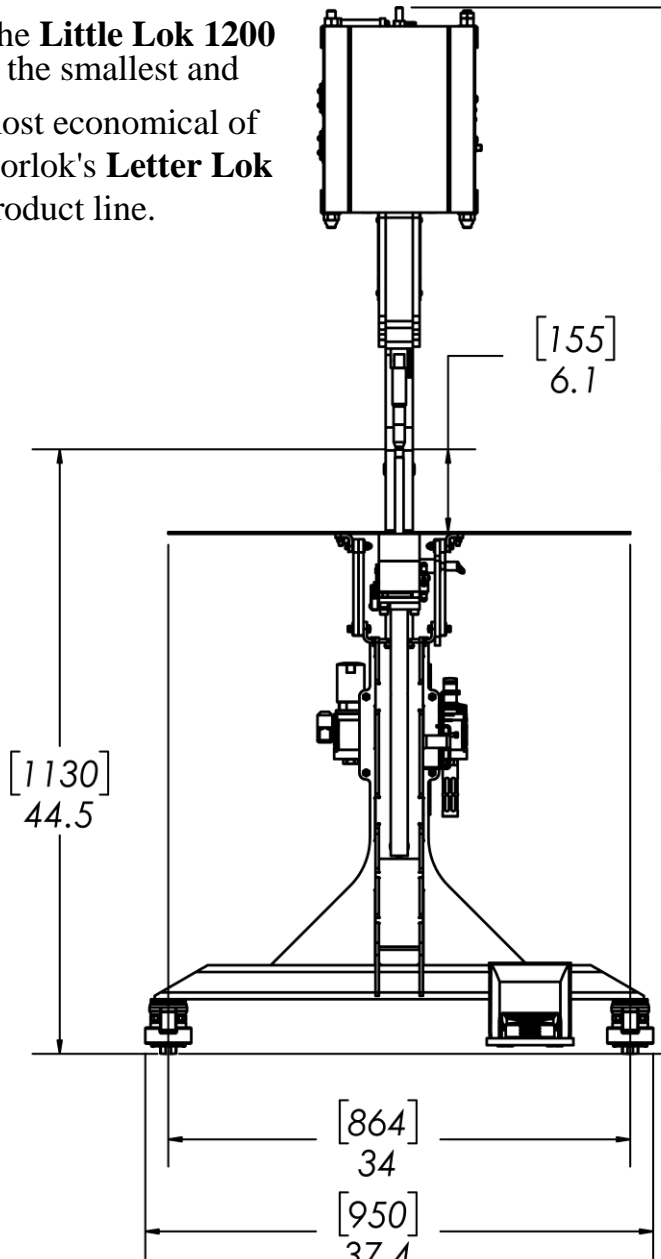

Lower stem rapidly moves out of the way via pneumatic cylinder

Leveling feet with wheels option available

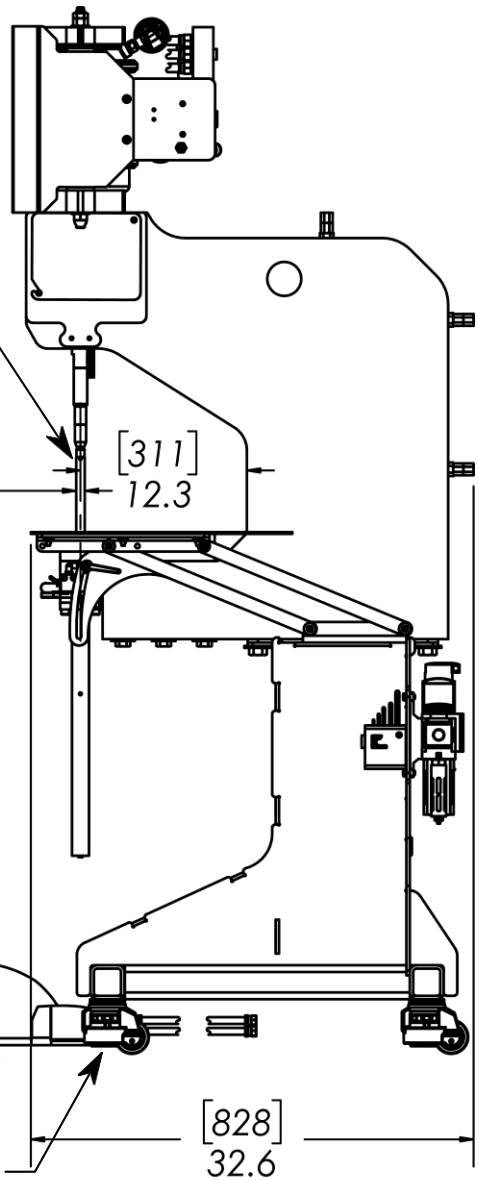

Stroke: 1/4" [6mm] operating
6" [150mm] low pressure opening

Throat: 12" [305mm]

Max Letter Height: 6" [150mm]

Table: 19" deep x 34" wide
[490 x 860 mm]

Cycle Speed: 80 CPM

Air Requirements: 70-100 psi [5-6.8 bar]
0.8 cu ft free air per cycle

Material	Joined With	Net Max Thickness	Net Min Thickness
Aluminum	Clinch/SPR	0.160" / 4mm *	0.048" / 2.00mm
TPO	SPR	Contact Norlok	
Galvanized Steel	Clinch/SPR	0.120" / 3.8mm *	.030" / 0.50mm
Aluminum Composite	SPR	Contact Norlok	

* Self Piercing Rivets (SPR) are sold by Norlok. SPR can join thicker material and produce stronger bonds compared to clinching